

2660 Series

THOMAS
by Gardner Denver

FEATURES

- > Custom configured part options
- > Oil-less operation
- > Permanently lubricated bearings
- > Stainless steel valves
- > Die-cast aluminum components
- > Dynamically balanced
- > Proven WOB-L technology
- > Monolithic head
- > Field service capability
- > Thermally protected motor
- > Designed and tested per Agency standards
- > RoHS compliant

Declaration documentation available upon request

TYPICAL APPLICATIONS

- > O₂ Concentrator
- > Blood & Laboratory Analyzers
- > Aspirators/Respirators
- > Dental & Optical Equipment
- > Industrial/Manufacturing Equipment
- > Business Equipment/Food & Beverage Equipment

BASE MODELS

2660E48XNTLSXX
(115/60/1)

2660N48XNTLSXX
(220-240/50/60/1)

2660S48XNTLSXX
(100/50/60/1)

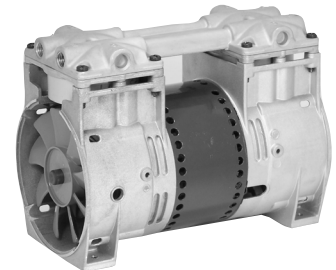

WOB-L

2660 Series

Flow	4.6 cfm (130.3 l/min)
Max. pressure	45 psi (3.1 bar)
Max. vacuum	92% local barometer

CONFIGURED OPTIONS

- > Stroke
- > Pump restart
- > Head port thread
- > Foot tap thread
- > Electrical cord
- > Fan guard
- > Protective cotating

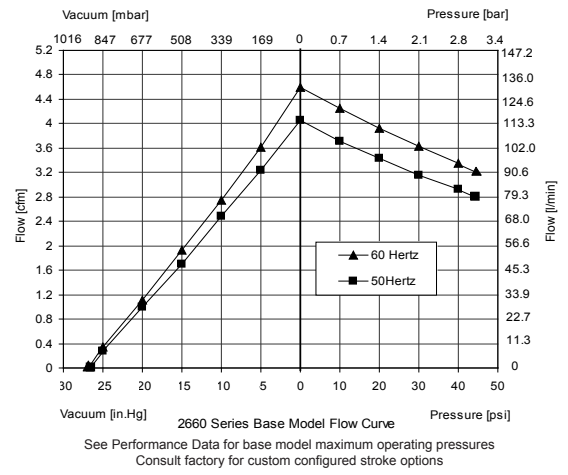
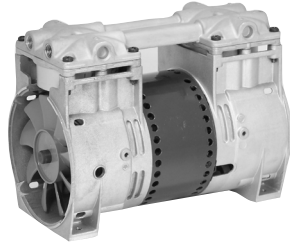

NOTE: All test values are nominal and for reference only. They are not guaranteed maximum or minimum limits, nor do they imply mean or median.

PERFORMANCE DATA	T10-0151	T10-0153		T10-0152	
Model Number	2660E48XNTLSXX	2660N48XNTLSXX		2660S48XNTLSXX	
Head Configuration	Pressure/vacuum parallel flow	Pressure/vacuum parallel flow		Pressure/vacuum parallel flow	
Stroke	0.48 in. (12.2 mm)	0.48 in. (12.2 mm)		0.48 in. (12.2 mm)	
Nominal voltage input	115/60/1	230/50/1	230/60/1	100/50/1	100/60/1
Max. open air flow	4.6 cfm (130.3 l/min)	4.0 cfm (113.3 l/min)	4.6 cfm (130.3 l/min)	4.0 cfm (113.3 l/min)	4.6 cfm (130.3 l/min)
Max. rated pressure	40 psi (2.8 bar)	45 psi (3.1 bar)	40 psi (2.8 bar)	25 psi (1.7 bar)	20 psi (1.4 bar)
Current at rated pressure	5.3A	2.5A	2.7A	4.5A	4.4A
Power at rated pressure	608W	523W	604W	421W	432W
Speed at rated pressure	1675 rpm	1409 rpm	1682 rpm	1436 rpm	1695 rpm
Max. pressure restart	Consult factory	Consult factory		Consult factory	
Max. vacuum	92% local barometer	92% local barometer		92% local barometer	
Max. vacuum restart	Consult factory	Consult factory		Consult factory	

ELECTRICAL DATA	P.S.C. [25 µF]		P.S.C. [15 µF]		P.S.C. [25 µF]	
Motor type (Capacitance)	P.S.C. [25 µF]		P.S.C. [15 µF]		P.S.C. [25 µF]	
Motor locked rotor current	18.0A		9.3A	8.3A	15.0A	14.5A
Motor insulation class	B		B		B	
Thermal switch (Open temperature)	Yes [293°F (145°C)]		Yes [248°F (120°C)]		Yes [293°F (145°C)]	
Lead wire color, gauge	Brown(hot), blue(neutral), 18 AWG		Brown(hot), blue(neutral), 18 AWG		Brown(hot), blue(neutral), 18 AWG	
Capacitor lead wire color, gauge	Black, black, 18 AWG		Red, red, 18 AWG		Black, black, 18 AWG	

GENERAL DATA	50° to 104°F (10°C TO 40°C)		50° to 104°F (10°C TO 40°C)		50° to 104°F (10°C TO 40°C)	
Operating ambient temperature*	50° to 104°F (10°C TO 40°C)		50° to 104°F (10°C TO 40°C)		50° to 104°F (10°C TO 40°C)	
Safety Certification	cRUus		TUV		None	
Net weight	17.6 lbs (8.0 kg)		17.1 lbs (7.8 kg)		17.6 lbs (8.0 kg)	

* Broader ambient operating ranges may be possible depending on your specific application. Please consult factory regarding your particular system needs.

PRODUCT DIMENSIONS

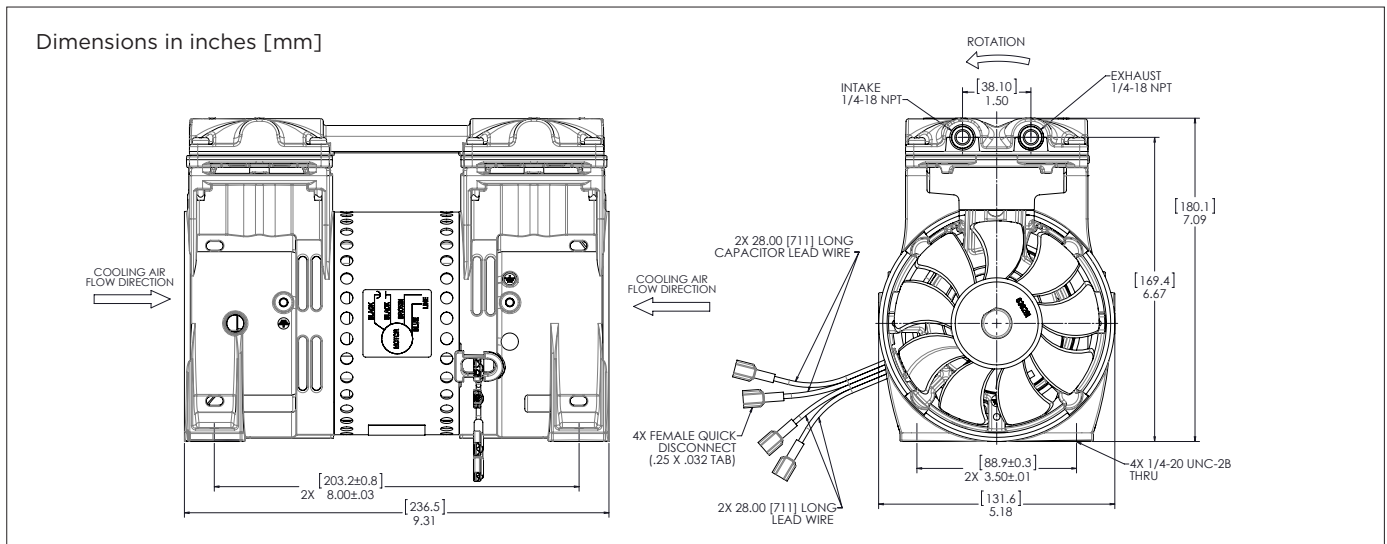

PUMP AND COMPRESSOR SOLUTIONS FOR OEMS WORLDWIDE

gd-thomas.com



Gardner Denver Thomas GmbH

Livry-Gargan-Str. 10
82256 Fürstfeldbruck
Germany

T +49 8141 2280 0

F +49 8141 8892136

thomas.de@gardnerdenver.com

Gardner Denver Hong Kong, Limited

Unit 1317-1318 Delta House, 3 On Yiu Street
Siu Lek Yuen, Shatin, New Territories
Hong Kong

T +852 26903502

F +852 27924598

thomas.hk@gardnerdenver.com

Gardner Denver Thomas, Inc.

1419 Illinois Avenue
Sheboygan, WI 53081
USA

T +1 920 4574891

F +1 920 4514276

td.usa@gardnerdenver.com

THOMAS
by Gardner Denver

The information presented in this material is based on technical data and test results of nominal units. It is believed to be accurate and reliable and is offered as an aid to help in the selection of Thomas products. It is the responsibility of the user to determine the suitability of the product for the intended use and the user assumes all risk and liability in connection there with. Thomas does not warrant, guarantee or assume any obligation or liability in connection with this information.

Models presented in this catalog are representative of the product family. Photos of products pictured in this catalog do not necessarily represent a specific model number. To obtain further information for custom options, contact your local Thomas office.

Printed in U.S.A Form No. 850-4009 06/2017 © Gardner Denver Thomas, Inc. All rights reserved.